



- Single phase AC 220VAC power noise filter
- Rated current: 1A-10A
- Noise filter for medical equipment (A)

Specification

- Rated Voltage: 110VAC-250VAC
- working frequency: 50/60HZ
- Rated Current: 1A-10A
- Withstand test voltage: 1750VAC
- Temperature range: -25°C~85°C
- Certificate: cUL,CQC,CE,ROHS
- Fire resistance: UL 94V-0

Characteristic

- IIEC general purpose socket input+ Filter circuit integrated design, small size and high performance.
- With high quality capacitor and high permeability Mn-Zn ferrite magnetic ring, excellent performance.
- It is good effective to solve the high frequency interference of 1Mhz to 30MHZ.
- There are a variety of parts combination collocation, to meet the requirement for testing different equipment.
- Can be customize according to customer requirements.

Application

- Medical equipment
- Testing equipment
- Fire extinguishing system
- Monitoring and control system

Products size

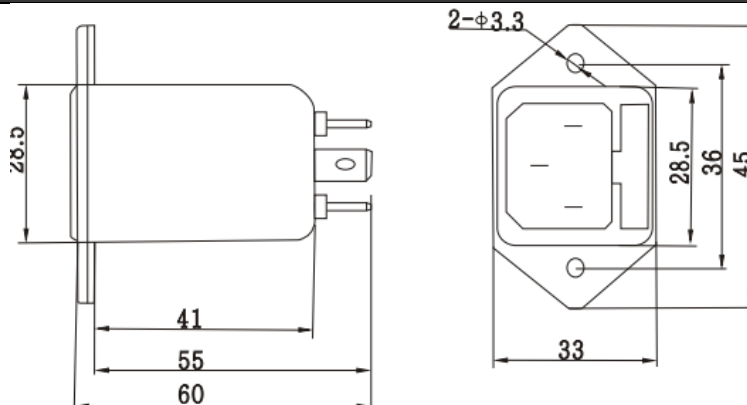

Electric schematic

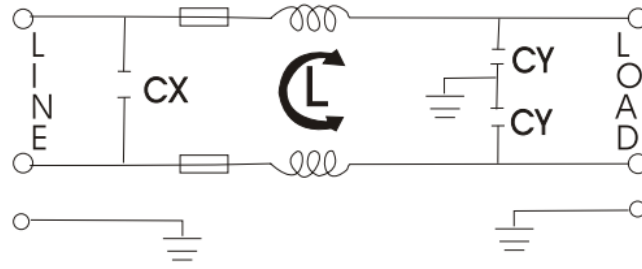

Specification

Model No. (A)	Rated current(A)	leakage current(mA)	Inductance (mH)	Capacitor		Resistor [k Ω]	Weight (g)
				Cx [pF]	Cy [nF]		
DAI2-1A	1	≤0.5	20	0.1	3.3	0	55g
DAI2-3A	3	≤0.5	2.5	0.1	3.3	0	55g
DAI2-6A	6	≤0.5	0.8	0.1	3.3	0	55g
DAI2-10A	10	≤0.5	0.3	0.1	3.3	0	55g

Insertion loss

Specification	(dB)	Frequency (MHz)					
		0.15	0.5	1	5	10	30
DAI2-1A	Common mode	36	49	49	51	54	58
	Differential mode	17	40	55	70	62	49
DAI2-3A	Common mode	31	44	55	53	55	60
	Differential mode	20	46	65	62	59	49
DAI2-6A	Common mode	25	35	41	51	58	51
	Differential mode	20	45	59	66	65	50
DAI2-10A	Common mode	24	38	50	67	63	50
	Differential mode	18	32	50	68	62	46

Insertion Loss

———— (Common Mode) - - - - - (Differential Mode)

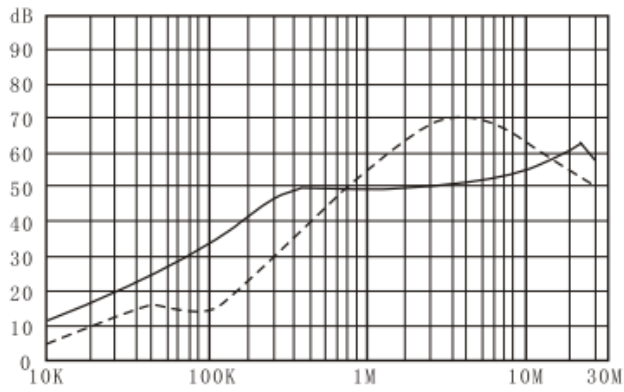

DAI2-1A

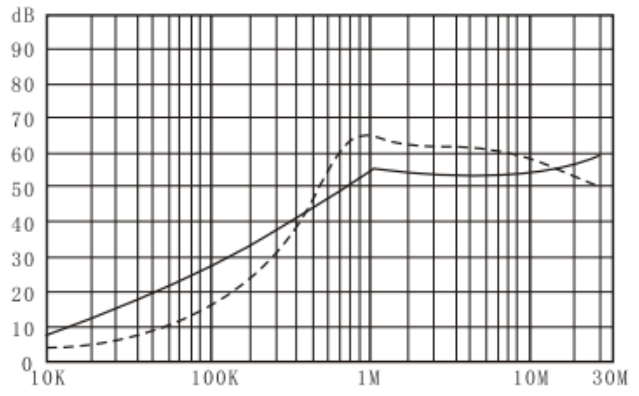

DAI2-3A

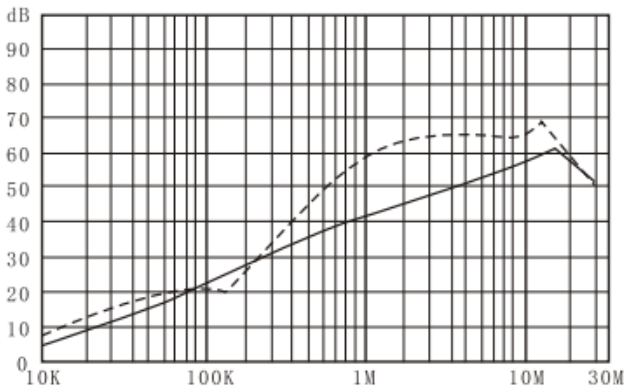

DAI2-6A

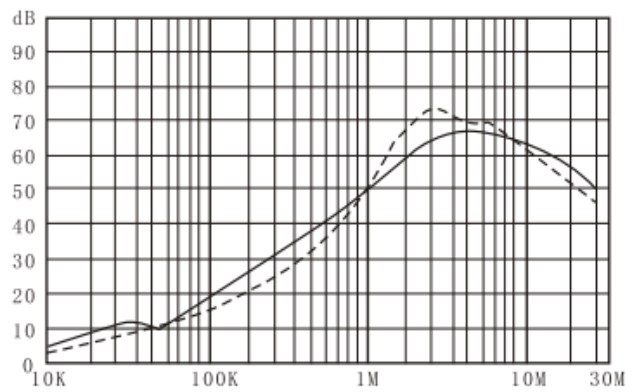

DAI2-10A